



## FMS-80-700 N-S LD-F

### 80W Constant Current -FMS Series



■ Approve



#### Features

- Class I , Non-isolated, Built-in
- Input Voltage :220-240VAC
- Protections: SCP/OVP/OTP
- Power Factor: 0.95(Typ.)
- Efficiency:  $\geq 90\%$ (Typ.)
- Adjustable Output Current with dip-switch
- 5 years warranty
- IP20

#### Applications

- Linear light

#### ◆ Description

FMS-80-700 N-S LD-F is a 80W constant current LED driver that operates from 176-264Vac input with 350 to 700mA output current. The output current is adjustable by DIP Switch. With it's dimensions from 280 x 30 x 21mm. It is easy to integrate in linear light products. To ensure trouble-free operation, protection is provided against output short circuit, over voltage and over temperature.

#### ◆ Model code

FMS-80-700 N-S LD-F

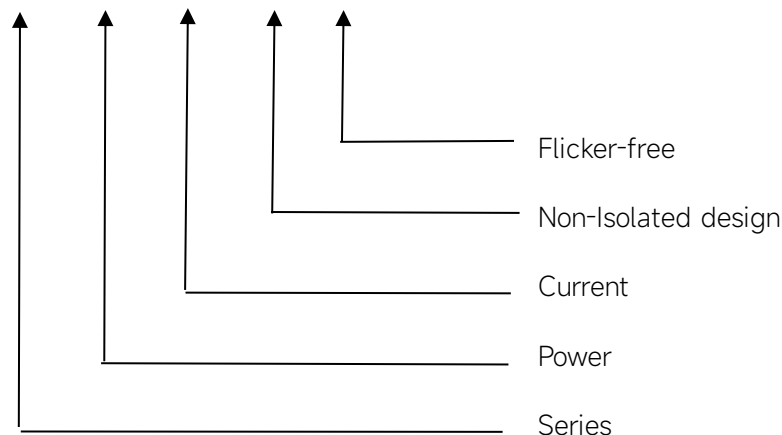

## ◆ Specification

Output	Constant Current	350mA	400mA	450mA	...mA	700mA
	Voltage Range	80-228VDC	80-200VDC	80-178VDC	...VDC	80-114VDC
	Unload voltage Max.(VDC)	280VDC				
	Current Accuracy	±5%				
	Output HF current ripple(≥1KHz)	±5%				
	Output LF current ripple(≤120Hz)	±5%				
	SVM	≤0.4				
	Pst	≤1				
	Efficiency(Typ.)	≥90%@Full load ,220-240V				
Input	Rated input voltage	220-240V				
	Range of input voltage	176-264VAC				
	Range of input DC voltage(VDC)	176-280VDC				
	Frequency(Hz)	0/50/60 Hz				
	Displacement factor	≥0.9				
	Power Factor	0.95@Full load ,220-240V				
	Input Current max	0.5A				
	Start-up time	< 0.5S				
	No Load Power	≤0.5W				
	THD (Typ.)	<10% @Full load ,220-240V				
Protection	Over Load Protection	103-130% YES/Auto Resume				
	Over Voltage Protection	YES/Auto Resume				
	Short circuit Protection	YES/Auto Resume				
	Over Temperature Protection	YES/Auto Resume Ta≥75° C, reducing the output current				
Capability	Surge capability (L-N)	1KV				
	Surge capability (L/N-Ground)	2KV				
Environment	Operating Temperature	-20°C ~+50°C				
	Humidity	20%-90% RH				
	Tc	80°C				
	Storage Temperature	-25°C ~+60°C				
	Life time	> 50000h@Tc=80°C ,230VAC				
	Noise	≤25dB(A)@20cm				
Surface	Dimension	280 x 30 x 21(LXWXH)mm				
	material	metal case				
Standards	Safety	EN61347- 1, EN61347-2- 13				
	EMC	EN55015, EN61000-3-2, EN61000-3-3, EN61547;EN61000-4-2,3,4,5,6,8,11, EN61547				
	ErP	Erp2.0 EU 2019/2020				



	RoHS	RoHS (2011/65/EU) (EU)2015/863
Note	<p>1.All parameters not specially mentioned are measured at 230VAC input, full load and 25°C of ambient temperature.</p> <p>2.Ripple &amp; Noise are measured at 20MHz of bandwidth by using a 300mm twisted pair-wire terminated with a 0.1uF &amp; 47 uF parallel capacitor.</p> <p>3.Switch and dimmer are not recommended to connect between this product output and luminaries.</p> <p>4.The current with load range cannot exceed 130% of the maximum power at full load.</p>	

## ◆ Parameter

Number	Output				Switch position		
	Current (mA)	Voltage (VDC)	Voltage No load (VDC)	Power (W)	1	2	3
1	350mA	80-228VDC	280VDC	79.8	--	--	--
2	400mA	80-200VDC		80	ON	--	--
3	450mA	80-178VDC		80.1	--	ON	--
4	500mA	80-160VDC		80	ON	ON	--
5	550mA	80-145VDC		79.75	--	--	ON
6	600mA	80-134VDC		80.4	ON	--	ON
7	650mA	80-123VDC		80	--	ON	ON
*8	700mA	80-114VDC		79.8	ON	ON	ON

\* Factory default

Preliminary

## ◆ Inrush Current

I <sub>peak</sub>	T <sub>width</sub>	B10	B16	B20	C10	C16	C20
33.8A	194μs	12pcs	20pcs	25pcs	16pcs	25pcs	32pcs

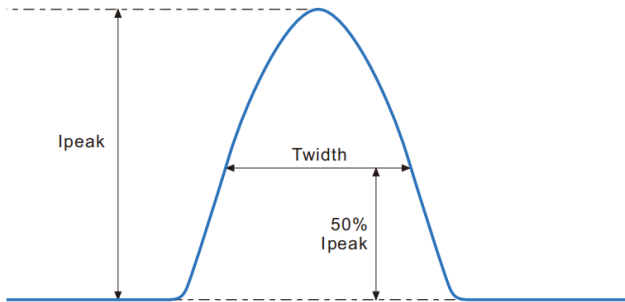

### Remarks:

- 1.The number of drives mounted under different MCBs in the table is the maximum value. Please do not exceed this number during installation.
- 2.Different brands and models of miniature circuit breakers, the number of drives mounted will be slightly different.

## ◆ Wiring diagram

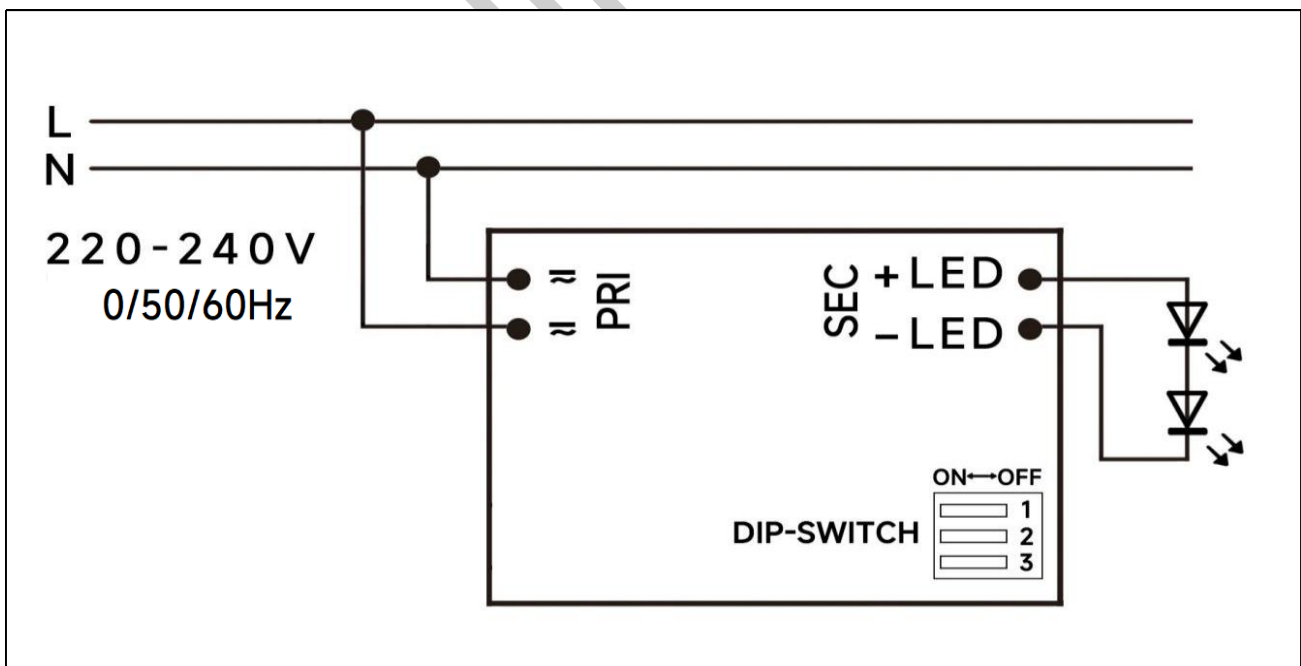

## ◆ 2D diagram

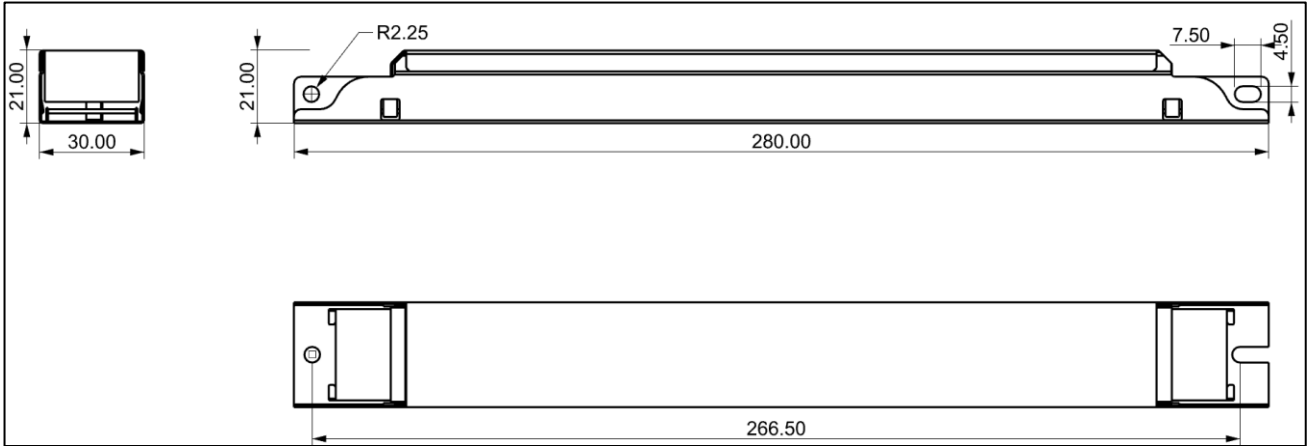

## ◆ Wiring & Connections

	Specification item	Value (Unit )
Input	Input wire cross-section	0.5...1.5 mm <sup>2</sup>
	Input wire gauge.	16...20 AWG
	Input wire strip length	7...9mm
Output	Output wire cross-section	0.5...1.5 mm <sup>2</sup>
	Output wire gauge.	16...20 AWG
	Output wire strip length	7...9mm

Note: Solid wire is risky to use on an angled terminal. Stranded wire is recommended for this kind of use.

# ◆ Curve for FMS-80-700 N-S LD-F, $I_o=700mA$

## Lifetime vs. Temperature Curve

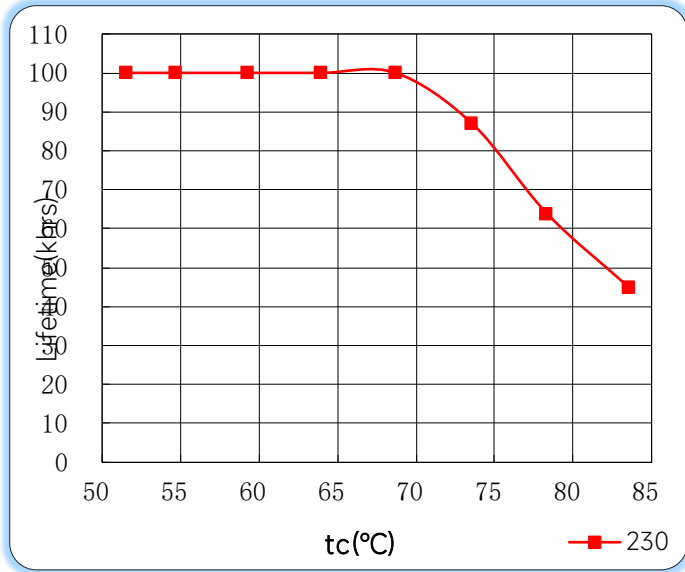

## Efficiency vs. Load

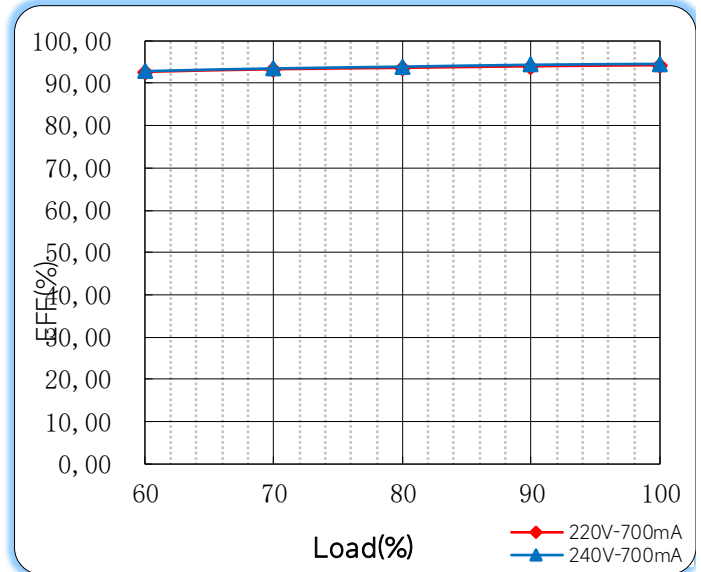

## Power Factor Characteristics

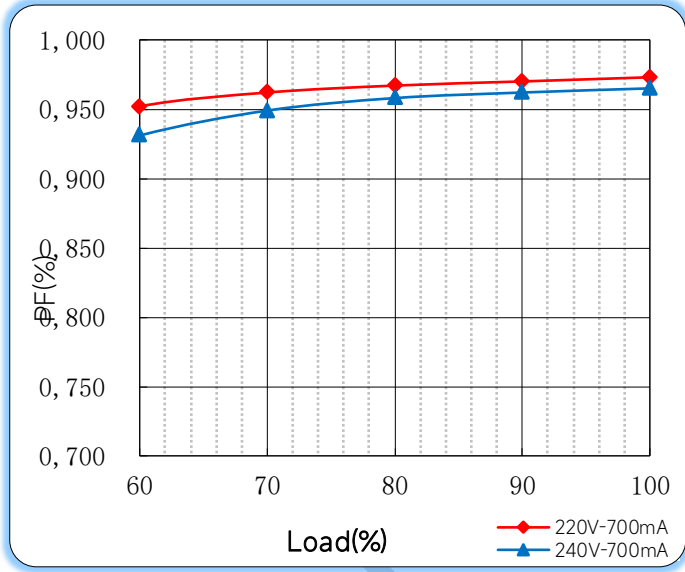

## THD vs. Load

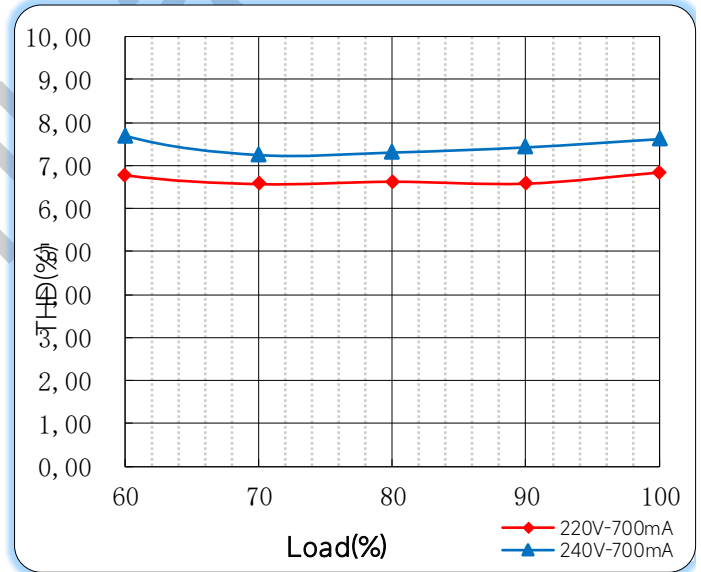

## ◆ Operating window

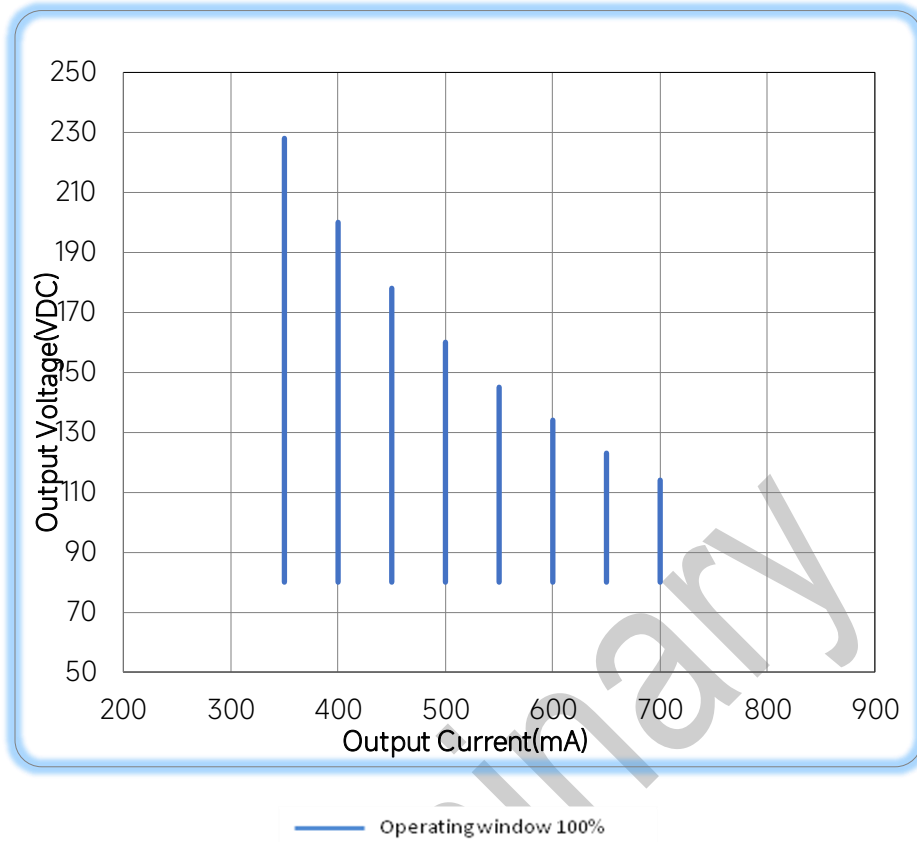

## ◆ Revision Updates

ITEM	BEFORE	AFTER	VERSION	DATE
Initial			A	2023/12/12

Remark: The final interpretation of the contents of the specification belongs to Eaglerise Electric & Electronic (China) Co., Ltd.



+7 (499) 647-80-74

zakaz@citi-el.ru